



Nikko-Rack™

QUICK ADJUSTABLE MAGAZINES PAT.

NIX,INC.

Super Nikko-Rack SIZE-M Assembly Manual

Notation	Article
Type1	R25, N25, SR25
Type2	T25

Read this manual carefully before assembly.

Operating precautions

- Do not use under any circumstances such as detergent, nut and bolt locker, grease, or other organic solvent. This might result in deformation or damage.
- Do not use this product as a stool to stand or sit on. Any such practice might damage the product, resulting in injury.
- Do not throw this products or apply a strong impact to it. This might result in deformation or damage.
- Do not expose this product to direct sunlight or ultraviolet radiation. Any such practice may result in deformation or damage.
- Before moving this product, be sure to check that the lever is locked. The moving parts may move when you least expect it, resulting perhaps in getting your finger or other part of your body caught.
- Do not put this product into a hot drying furnace. Any such practice might result in deformation or damage.
- When reassembling or otherwise handling this product, be careful about the sharp tips of the parts. They may result in injury.

List of parts All photos represent Type1. (The parts of Type 2 are different in shapes and specifications.)

①-A Guide rail unit A ...1unit

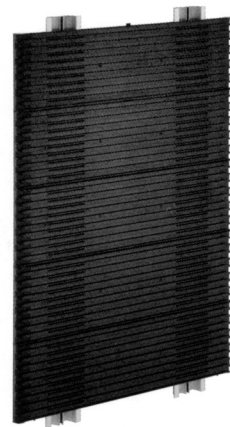

①-B Guide rail unit B ...1unit

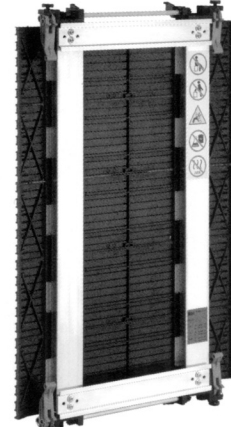

② Base 2pcs

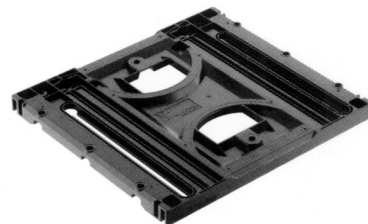

*For Type 1, the two bases (top and bottom plates) are identical.
*For Type 2, the top plate is differently shaped from the bottom plate. Take care not to confuse them.

③ Guide channel U 2pcs (4 pcs for Type 2)



④ Hexagon socket head cap screw M6×16 8pcs (12 pcs for Type 2)



⑤ Flat washer ... 8pcs (12 pcs for Type 2)

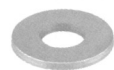

⑥ Spacer 2pcs (designed specifically for Type 2)

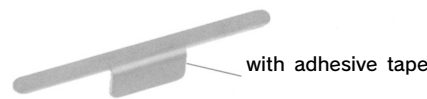

Composition of parts.

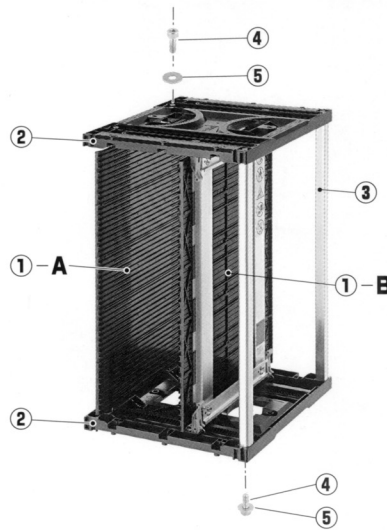

For questions about this product, please contact : ☎ +81-45-221-1350

Assembly procedure *Assemble the parts in numerical order : ① to ④.

1 Installing guide channel U.

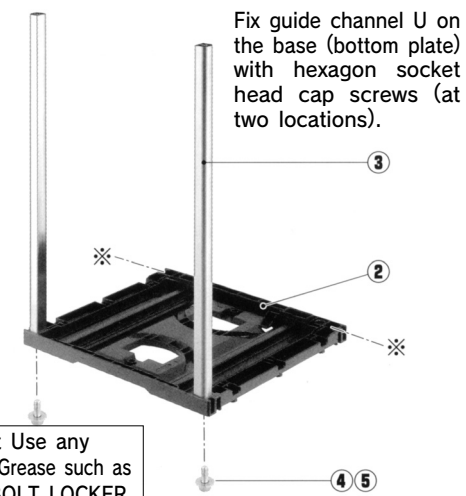

Do Not Use any chemical or Grease such as NUT and BOLT LOCKER

For Type 2 (with four guide channel U's), install them at the locations marked * as well.

2 Installing guide rail unit A

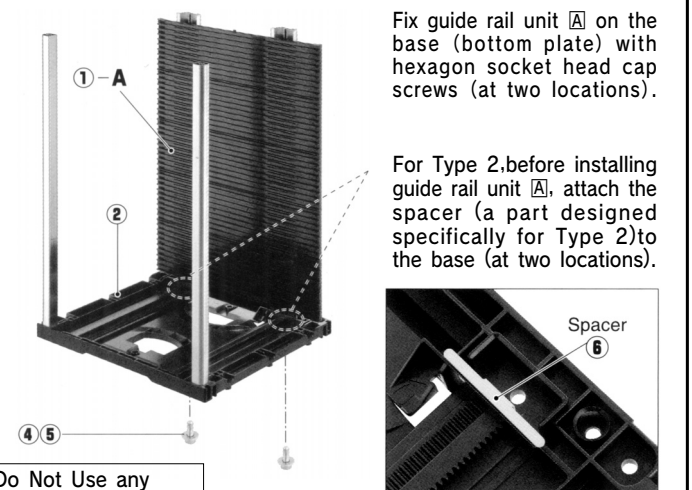

Do Not Use any chemical or Grease such as NUT and BOLT LOCKER

3 Installing guide rail unit B

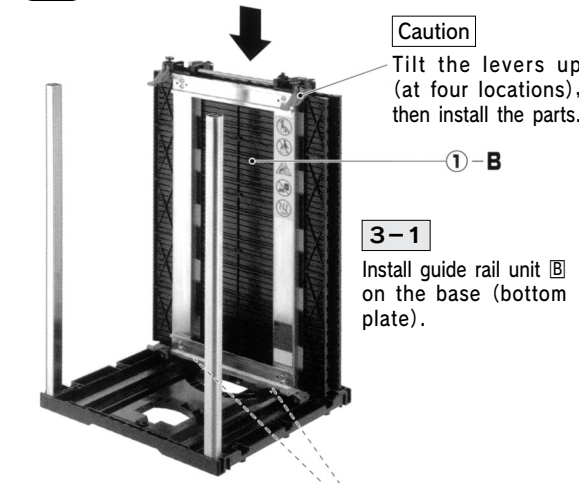

At that time, fit the lug at the bottom of Unit B into the groove in the base (see the right-hand side of the photo).

Guide rail unit B

Base (bottom plate)

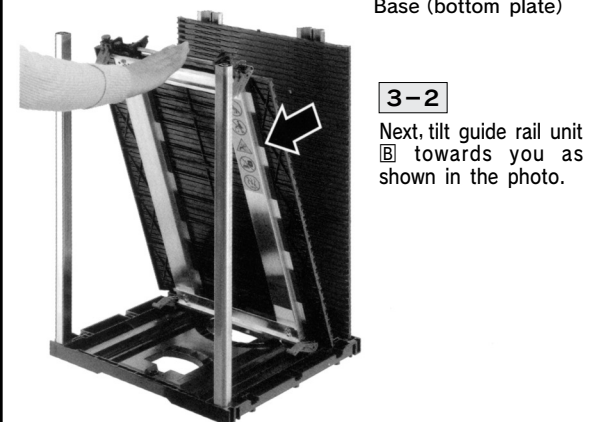

4 Installing the base (top plate)

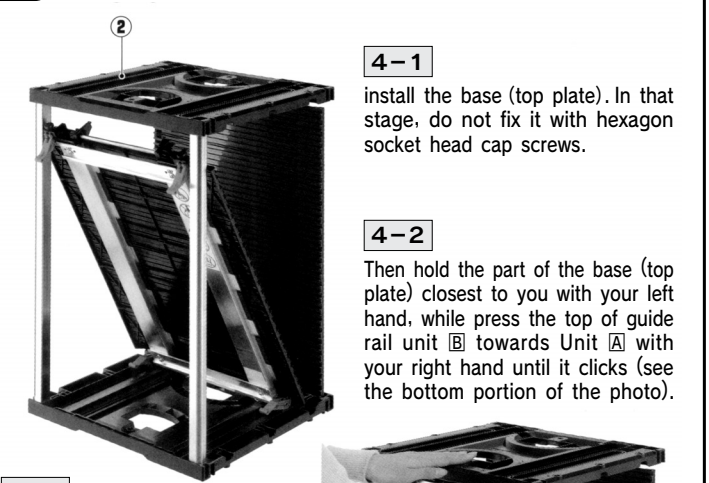

4-3 Press the floating base (top plate) from above, thus making it so that the pin of Unit B becomes visible.

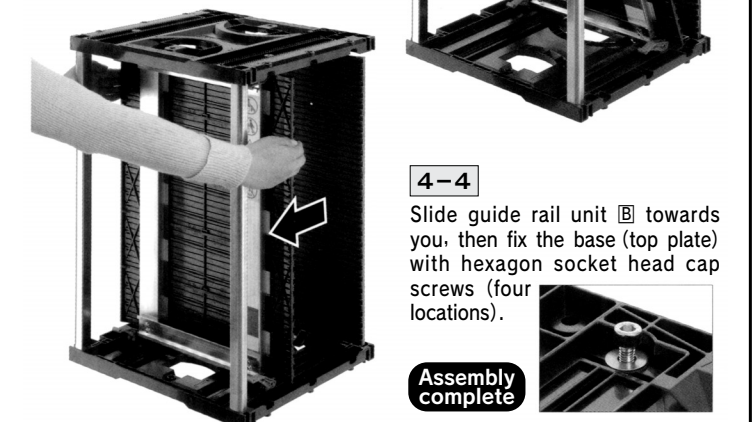

Assembly complete